

00974

**DF8 Series
Pendant Dome**

**Maintenance/
Service Manual**

C2433SM-A (8/02)

CONTENTS

<u>Section</u>	<u>Page</u>
IMPORTANT SAFEGUARDS AND WARNINGS	3
DESCRIPTION	4
MODELS	4
MAINTENANCE	4
EXPLODED ASSEMBLY DIAGRAMS	5
WARRANTY AND RETURN INFORMATION	8

LIST OF ILLUSTRATIONS

<u>Figure</u>	<u>Page</u>
1 Exploded Assembly Diagram–DF8 Pendant Models	5
2 Exploded Assembly Diagram–Heater and Fan Assembly (Outdoor Models Only) ..	6
3 Exploded Assembly Diagram–Pendant Lower Dome	7

LIST OF TABLES

<u>Table</u>	<u>Page</u>
A Exploded Assembly Parts List–DF8 Pendant Models	5
B Exploded Assembly Parts List–Heater and Fan Assembly (Outdoor Models Only) ..	6
C Exploded Assembly Parts List–Pendant Lower Dome	7

IMPORTANT SAFEGUARDS AND WARNINGS

Prior to installation and use of this product, the following WARNINGS should be observed.

1. Read these instructions.
2. Keep these instructions.
3. Heed all warnings.
4. Follow all instructions.
5. Do not block any ventilation openings. Install in accordance with the manufacturer's instructions.
6. Do not install near any heat sources, such as radiators, heat registers, stoves, or other apparatus (including amplifiers) that produce heat.
7. Only use attachments/accessories specified by the manufacturer.
8. Use only with the cart, stand, tripod, bracket, or table specified by the manufacturer or sold with the apparatus. When a cart is used, use caution when moving the cart/apparatus combination to avoid injury from tip-over.
9. Refer all servicing to qualified service personnel. Servicing is required when the apparatus has been damaged in any way, such as power-supply cord or plug is damaged, liquid has been spilled or objects have fallen into the apparatus, the apparatus has been exposed to rain or moisture, the apparatus does not operate normally, or the apparatus has been dropped.
10. To reduce the risk of shock, do not perform any servicing other than that contained in the operating instructions unless you are qualified to do so.
11. The installation method and materials should be capable of supporting four times the weight of the unit and equipment.
12. Only use replacement parts recommended by Pelco.
13. After replacement/repair of this unit's electrical components, conduct a resistance measurement between line and exposed parts to verify the exposed parts have not been connected to line circuitry.

The product and/or manual may bear the following marks:



This symbol indicates that dangerous voltage constituting a risk of electric shock is present within this unit.



This symbol indicates that there are important operating and maintenance instructions in the literature accompanying this unit.

CAUTION:

RISK OF ELECTRIC SHOCK.
DO NOT OPEN.

Please thoroughly familiarize yourself with the information in this manual prior to installation and operation.

DESCRIPTION

DF8 Series pendant domes are discreet surveillance domes that are designed for indoor or outdoor use.

MODELS

DF8-PB-0	Indoor, black, fixed mount pendant dome, black opaque lower dome with smoked viewing window (1/2 f-stop of light loss)
DF8-PB-1	Same as DF8-PB-0, except clear viewing window (virtually no light loss)
DF8-PB-2	Same as DF8-PB-0, except chrome lower dome (2 f-stops of light loss)
DF8-PB-3	Same as DF8-PB-0, except gold lower dome (2 f-stops of light loss)
DF8-PG-0	Indoor, gray, fixed mount pendant dome, black opaque lower dome with smoked viewing window (1/2 f-stop of light loss)
DF8-PG-1	Same as DF8-PG-0, except clear viewing window (virtually no light loss)
DF8-PG-2	Same as DF8-PG-0, except chrome lower dome (2 f-stops of light loss)
DF8-PG-3	Same as DF8-PG-0, except gold lower dome (2 f-stops of light loss)
DF8-PG-E0	Outdoor, gray, fixed mount pendant dome, heater and blower, black opaque lower dome with smoked viewing window (1/2 f-stop of light loss)
DF8-PG-E1	Same as DF8-PG-E0, except clear viewing window (virtually no light loss)

MAINTENANCE

Clean the acrylic dome as necessary to maintain a clear picture. Be careful not to scratch the surfaces of the dome.

Exterior Surface – Clean the dome's exterior surface with a nonabrasive cleaning cloth and cleaning agent that is safe for acrylic plastic. Either liquid or spray cleaner/wax suitable for fine furniture is acceptable.

Interior Surface (Except Chrome or Gold) – Clean the same as the exterior surface.

Interior Surface (Chrome or Gold) – The inside surface of a chrome or gold dome is easily scratched. Use the following precautions to maintain the dome's surface.

1. Always handle the dome from the outside of its circular flange.
2. Never touch the coated inside surface. The acid in your fingerprints will eventually etch the coating if the fingerprints are not carefully removed according to the recommended cleaning procedure in item 5.
3. If dust or other contaminants accumulate on the dome's interior, remove the debris with compressed air. Compressed air cans are available from photographic equipment or electronic supply dealers.
4. If heavy residue accumulates and cannot be removed with air pressure, rinse with water and immediately dry with air pressure so that water spots will not remain. Avoid wiping the coated surface with direct hand pressure – it will easily abrade unless extreme care is taken. Once scratched, the dome cannot be recoated.
5. If internal wiping is necessary, avoid hand rubbing. Instead, make a wick as follows:

Use a very soft paper towel. Roll a section into a tightly wound tube. Tear the tube in half, and wet the fuzzy end of the wick with a solution of isopropyl alcohol diluted with water. Hold the dome with its opening facing downward and wipe the interior of the dome with the wet end of the wick. Use a circular motion, starting from the outside and spiraling into the center. Use a new wick for each two passes over the dome.

EXPLODED ASSEMBLY DIAGRAMS

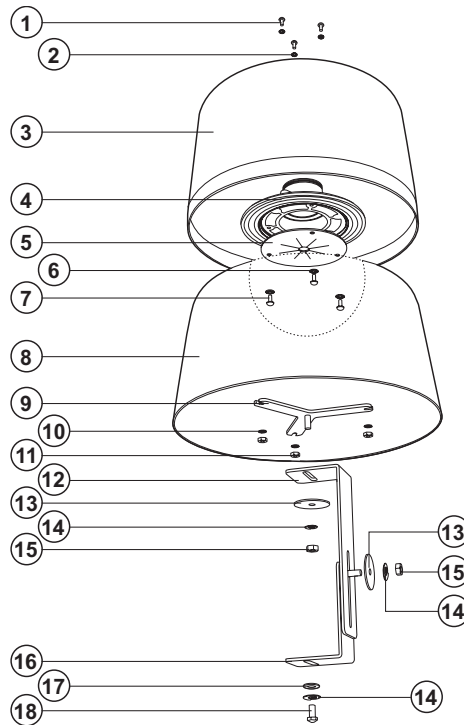

Figure 1. Exploded Assembly Diagram—DF8 Pendant Models

Table A. Exploded Assembly Parts List—DF8 Pendant Models

Item	Qty	Description	Part Number
1	3	Screw, 6-32 x 5/16", pan head, Phillips, gray, with plastic washer (outdoor models only)	ZH6-32X.312GRAY
2	3	Internal tooth lock washer, #6 (outdoor models only)	ZH6LWSIS
3	1	Sun shield (outdoor models only)	MF02-3020-007
4	1	Top mount, black	MF03-7060-174
		Top mount, gray	MF02-7060-174
5	1	Gasket	70610012
6	3	Internal tooth lock washer, #8	ZH8LWSIS
7	3	Screw, 8-32 x 3/8", pan head, Phillips	ZH8-32X.375SPP
8	1	Back box, black	MF03-3021-005
		Back box, gray	MF02-3021-005
9	1	Base plate	PDF54000COMP
10	3	Internal tooth lock washer, #8	ZH8LWSIS
11	3	Nut, 8-32	ZH8-32NUTSH
12	1	Tilt table support leg	MF03-3020-002
13	2	Fender washer, 1/4"	ZH25X1.50X625
14	3	Split lock washer, 1/4"	ZH1/4LWSSL
15	2	Nut, 1/4-20	ZH1/420NUTCH
16	1	Tilt table	MF03-3021-003
17	1	Flat washer, 3/16"	ZH260X562X65C
18	1	Screw, 1/4-20 x 1/2"	ZH1/420X.500CH
NS	1	Trim leash assembly attached to side of back box	
		Leash	7061005
		Internal tooth lock washer, #6	ZH6LWSIS
		Nut, 6-32	ZH6-32NUTSH
		Nylon cable clamp (outdoor models only)	ZH8911

NS = Not shown

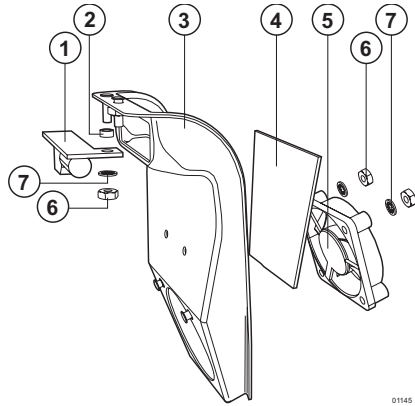

Figure 2. Exploded Assembly Diagram—Heater and Fan Assembly (Outdoor Models Only)

Table B. Exploded Assembly Parts List—Heater and Fan Assembly (Outdoor Models Only)

Item	Qty	Description	Part Number
1	1	Circuit board, fan rectifier	PCB9000277BASSY
2	1	Spacer, 3/16" diameter x .125", #4	SPA9015
3	2	Fan/heater shroud	MF01-1041-013
4	2	Heater pad, 24 VAC, 15W	HT01-0321-0202
5	2	Fan, 12 VDC, .7W, 7 cfm	ZH65-1240-1044
6	7	Nut, 4-40	ZH4-40NUTSH
7	7	Internal tooth lock washer, #4	ZH4LWSIS
NS	1	Power/heater circuit board on side of back box Includes thermostat On at 40°F (4°C) Off at 60°F (16°C) Spacer, .250" outside diameter x .125", #6 Internal tooth lock washer, #6 Nut, 6-32	PCB9000300ASSY SPA8500 ZH6LWSIS ZH6-32NUTSH

NS = Not shown

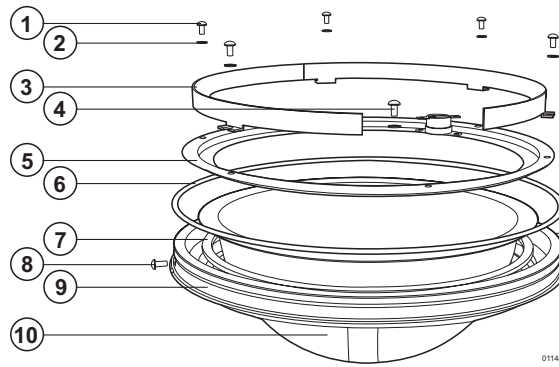

Figure 3. Exploded Assembly Diagram–Pendant Lower Dome

Table C. Exploded Assembly Parts List–Pendant Lower Dome

Item	Qty	Description	Part Number
1	5	Screw, 6-32 x 1/4", pan head, Phillips (indoor models only)	ZH6-32X.250SPP
2	5	Screw, 6-32 x 3/8", pan head, Phillips (outdoor models only)	ZH6-32X.375SPP
3	6	Internal tooth lock washer, #6	ZH6LWSIS
4	1	DF8 Heater Ring Assembly (outdoor models only) 24 VAC, 60W Includes thermostat On at 70°F (21°C) Off at 85°F (29°C)	3023-004A
5	1	Screw, 6-32 x 1/4", pan head, Phillips	ZH6-32X.250SPP
6	1	Lower dome retainer	MF00-3020-006
7	1	O-ring	ZH69-0105-2756
8	1	Trim ring gasket	GS01-0002-0430
9	2	Screw, 6-32 x 5/16", pan head, Phillips, gray, with plastic washer	ZH6-32X.312GRAY
10	1	Trim ring, black	MF03-3020-010
		Trim ring, gray	MF02-3020-010
		Acrylic dome, black opaque with smoked viewing window	80810015-00
		Acrylic dome, black opaque with clear viewing window	80810015-01
		Acrylic dome (chrome)	80810011-2
		Acrylic dome (gold)	80810011-3

PRODUCT WARRANTY AND RETURN INFORMATION

WARRANTY

Pelco will repair or replace, without charge, any merchandise proved defective in material or workmanship **for a period of one year** after the date of shipment.

Exceptions to this warranty are as noted below:

- Five years on FT/FR8000 Series fiber optic products.
- Three years on Genex® Series products (multiplexers, server, and keyboard).
- Three years on Camclosure® and fixed camera models, except the CC3701H-2, CC3701H-2X, CC3751H-2, CC3651H-2X, MC3651H-2, and MC3651H-2X camera models, which have a five-year warranty.
- Two years on standard motorized or fixed focal length lenses.
- Two years on Legacy®, CM6700/CM6800/CM9700 Series matrix, and DF5/DF8 Series fixed dome products.
- Two years on Spectra®, Esprit®, ExSite™, and PS20 scanners, including when used in continuous motion applications.
- Two years on Esprit® and WW5700 Series window wiper (excluding wiper blades).
- Eighteen months on DX Series digital video recorders, NVR300 Series network video recorders, and Endura™ Series distributed network-based video products.
- One year (except video heads) on video cassette recorders (VCRs). Video heads will be covered for a period of six months.
- Six months on all pan and tilts, scanners or preset lenses used in continuous motion applications (that is, preset scan, tour and auto scan modes).

Pelco will warrant all replacement parts and repairs for 90 days from the date of Pelco shipment. All goods requiring warranty repair shall be sent freight prepaid to Pelco, Clovis, California. Repairs made necessary by reason of misuse, alteration, normal wear, or accident are not covered under this warranty.

Pelco assumes no risk and shall be subject to no liability for damages or loss resulting from the specific use or application made of the Products. Pelco's liability for any claim, whether based on breach of contract, negligence, infringement of any rights of any party or product liability, relating to the Products shall not exceed the price paid by the Dealer to Pelco for such Products. In no event will Pelco be liable for any special, incidental or consequential damages (including loss of use, loss of profit and claims of third parties) however caused, whether by the negligence of Pelco or otherwise.

The above warranty provides the Dealer with specific legal rights. The Dealer may also have additional rights, which are subject to variation from state to state.

If a warranty repair is required, the Dealer must contact Pelco at (800) 289-9100 or (559) 292-1981 to obtain a Repair Authorization number (RA), and provide the following information:

1. Model and serial number
2. Date of shipment, P.O. number, Sales Order number, or Pelco invoice number
3. Details of the defect or problem

If there is a dispute regarding the warranty of a product which does not fall under the warranty conditions stated above, please include a written explanation with the product when returned.

Method of return shipment shall be the same or equal to the method by which the item was received by Pelco.

RETURNS

In order to expedite parts returned to the factory for repair or credit, please call the factory at (800) 289-9100 or (559) 292-1981 to obtain an authorization number (CA number if returned for credit, and RA number if returned for repair).

All merchandise returned for credit may be subject to a 20% restocking and refurbishing charge.

Goods returned for repair or credit should be clearly identified with the assigned CA or RA number and freight should be prepaid. Ship to the appropriate address below.

If you are located within the continental U.S., Alaska, Hawaii or Puerto Rico, send goods to:

Service Department
Pelco
3500 Pelco Way
Clovis, CA 93612-5699

If you are located outside the continental U.S., Alaska, Hawaii or Puerto Rico and are instructed to return goods to the USA, you may do one of the following:

If the goods are to be sent by a COURIER SERVICE, send the goods to:

Pelco
3500 Pelco Way
Clovis, CA 93612-5699 USA

If the goods are to be sent by a FREIGHT FORWARDER, send the goods to:

Pelco c/o Expeditors
473 Eccles Avenue
South San Francisco, CA 94080 USA
Phone: 650-737-1700
Fax: 650-737-0933

REVISION HISTORY

Manual #	Date	Comments
C2433SM	9/01	Original version.
C2433SM-A	8/02	Added certifications. Revised <i>Important Safeguards and Warnings</i> .

Pelco, the Pelco logo, Camclosure, Esprit, Genex, Legacy, and Spectra are registered trademarks of Pelco. Endura and ExSite are trademarks of Pelco.

© Copyright 2002, Pelco.
All rights reserved.